

CAMPBELL'S CONCRETE LTD.
420 MT. EDWARD ROAD, P.O. BOX 373 • CHARLOTTETOWN, P.E.I. C1A 7K7

C11.0

FLOWER PLANTER

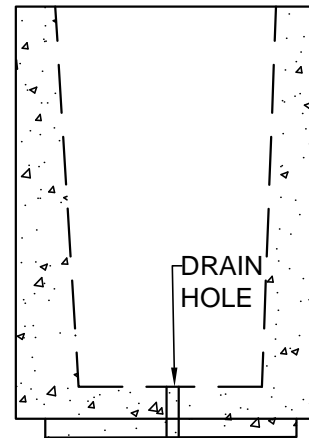
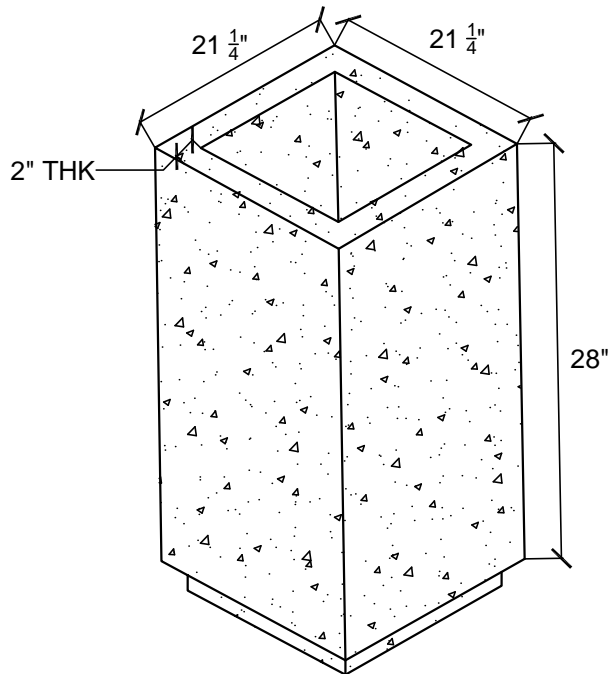

ITEM # C11.001
WEIGHT 640 LB

SPECIFICATIONS:
5000 psi AT 28 DAYS
AIR ENTRAINING 5-7%

NOTES: CONCRETE DOES NOT RUST, CORRODE OR DETERIORATE
PLANTER HAS A DRAIN HOLE TO ALLOW FOR EXCESS WATER TO PASS
A LOW MAINTENANCE SOLUTION TO DECORATIVE NEEDS
FOR ALL SEASON USE, PLANTER SHOULD BE LINED WITH STYROFOAM
TO ALLOW FOR SOIL EXPANSION