

CAMPBELL'S CONCRETE LTD.

420 MT. EDWARD ROAD, P.O. BOX 373 • CHARLOTTETOWN, P.E.I. C1A 7K7

W2.6

3000 IGAL SEPTIC TANK

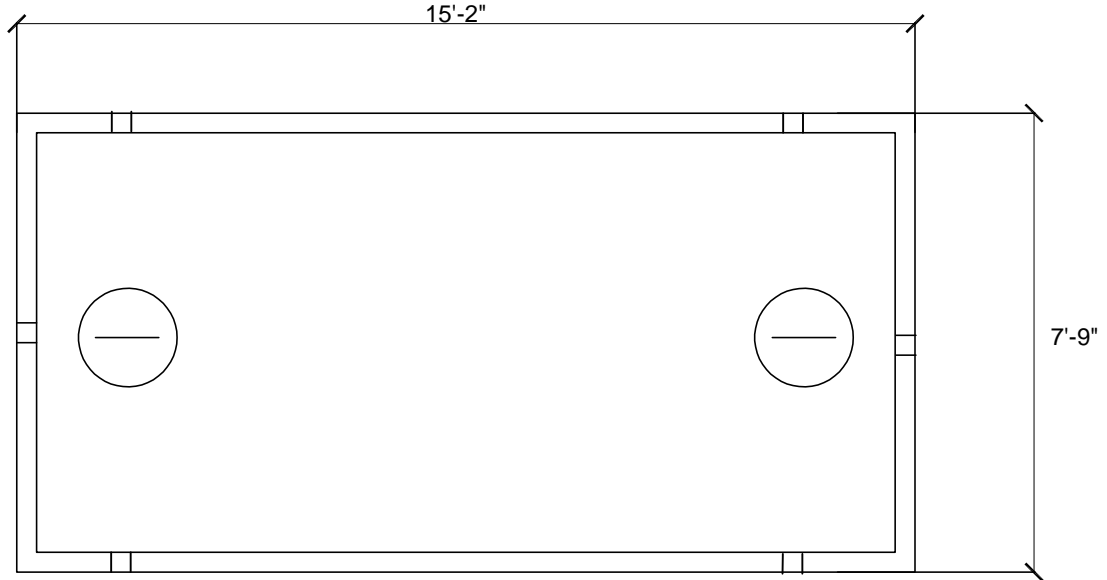

TOP VIEW

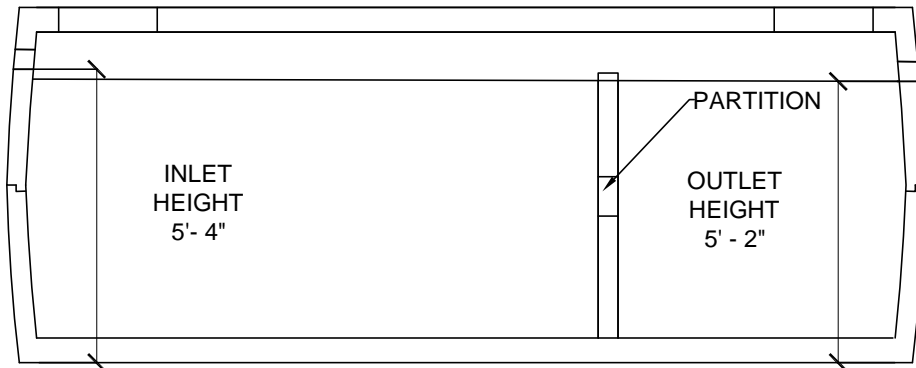

CROSS SECTION

SPECIFICATIONS:
 APPROVED BY PEI DEPT. OF ENVIRONMENT
 5000 psi AT 28 DAYS
 AIR ENTRAINING 5-7%
 10mm REBAR REINFORCING
 FIBRE MESH REINFORCING

NOTES: - PARTITION WALL CONTAINS AN 8"X 8" OPENING CENTERED ON LIQUID LEVEL
 -PARTITION EXTENDS 1 1/2" ABOVE LIQUID LEVEL

DESCRIPTION	ITEM #	OUTSIDE DIMENSIONS			THICKNESS			INLET	OUTLET	WEIGHT
		H	W	L	WALL	FLOOR	TOP			
3000 GAL SEPTIC TANK	W2.601	6'-6"	7'-1"	14'-6"	4"	5"	5"	5'-4"	5'-2"	27900